



Standard Safety and Performance Specification for Soccer Goals¹

This standard is issued under the fixed designation F2950; the number immediately following the designation indicates the year of original adoption or, in the case of revision, the year of last revision. A number in parentheses indicates the year of last reapproval. A superscript epsilon (ϵ) indicates an editorial change since the last revision or reapproval.

1. Scope

1.1 This standard specifies safety and performance requirements aimed at providing safer soccer goals and thereby reducing injuries and fatalities.

1.2 This standard applies to all soccer goals with a total weight greater than 40 lb when weighed in accordance with 7.1.1 and 7.1.2.

1.3 This standard supersedes Specification F2056-09.

1.4 This standard supersedes Specification F2673-08.

1.5 The values stated in inch-pound units are to be regarded as standard. No other units of measurement are included in this standard.

1.6 *This standard does not purport to address all of the safety concerns, if any, associated with its use. It is the responsibility of the user of this standard to establish appropriate safety and health practices and determine the applicability of regulatory limitations prior to use.*

2. Referenced Documents

2.1 *ASTM Standards:*²

F1487 Consumer Safety Performance Specification for Playground Equipment for Public Use

F2056 Safety and Performance Specification for Soccer Goals

F2673 Safety Specification for Special Tip-Resistant Movable Soccer Goals

2.2 *Other Standards:*

ANSI Z535.4 Guidelines for the Design and Safety Signs and labels for Application to Products

EN 748 Playing field equipment – Football goals – Functional and safety requirements, test 57 methods

3. Terminology

3.1 *Definitions:*

¹ This specification is under the jurisdiction of ASTM Committee F15 on Consumer Products and is the direct responsibility of Subcommittee F15.43 on Soccer Goal Safety.

Current edition approved April 1, 2014. Published July 2014. DOI: 10.1520/F2950-14.

² For referenced ASTM standards, visit the ASTM website, www.astm.org, or contact ASTM Customer Service at service@astm.org. For *Annual Book of ASTM Standards* volume information, refer to the standard's Document Summary page on the ASTM website.

3.1.1 *base frame, n*—portion of the goal frame consisting of the left base, right base, and back bottom bar.

3.1.2 *crush or shear point, n*—any point that entraps at one or more positions a 0.62 in. diameter rod.

3.1.3 *movable goal, n*—any free-standing soccer goal designed to be readily moved from location of use to location of use. If a goal is able to function as a soccer goal without the use of anchors or support of other structure, it must be considered a movable goal.

3.1.4 *permanent goal, n*—any goal fixed by concrete or other material to ground or floor, with or without net supports. Cannot be relocated for use.

3.1.5 *semi permanent goal, n*—any goal designed to be inserted into a ground sleeve or readily fastened to a supporting structure and thereby able to be removed from the location of use.

3.1.6 *upright frame, n*—portion of the goal frame consisting of the left upright, right upright, crossbar and backstays.

3.2 See Fig. 1 for goal component definitions.

4. Material

4.1 The goal frame may be made of any material, provided the requirements of this standard are fulfilled.

4.2 All materials related to the construction of the goal frames (net excluded) shall be designed to maintain their integrity for outdoor use for a minimum period of five years when maintained according to manufacturer's instruction and schedule.

5. Design

5.1 The uprights and the crossbar shall have the same cross section.

5.2 The cross section of the side parts of the base frame shall not extend outside of the uprights at the point where the base frame meets the upright.

5.3 There shall be no crush or shear points caused by junctures of two or more components where at least one of the components moves in relation to the opposing component(s).

5.4 All exposed corners and edges shall be rounded with a radius of at least 0.12 in.

5.5 All tubing ends shall be covered.

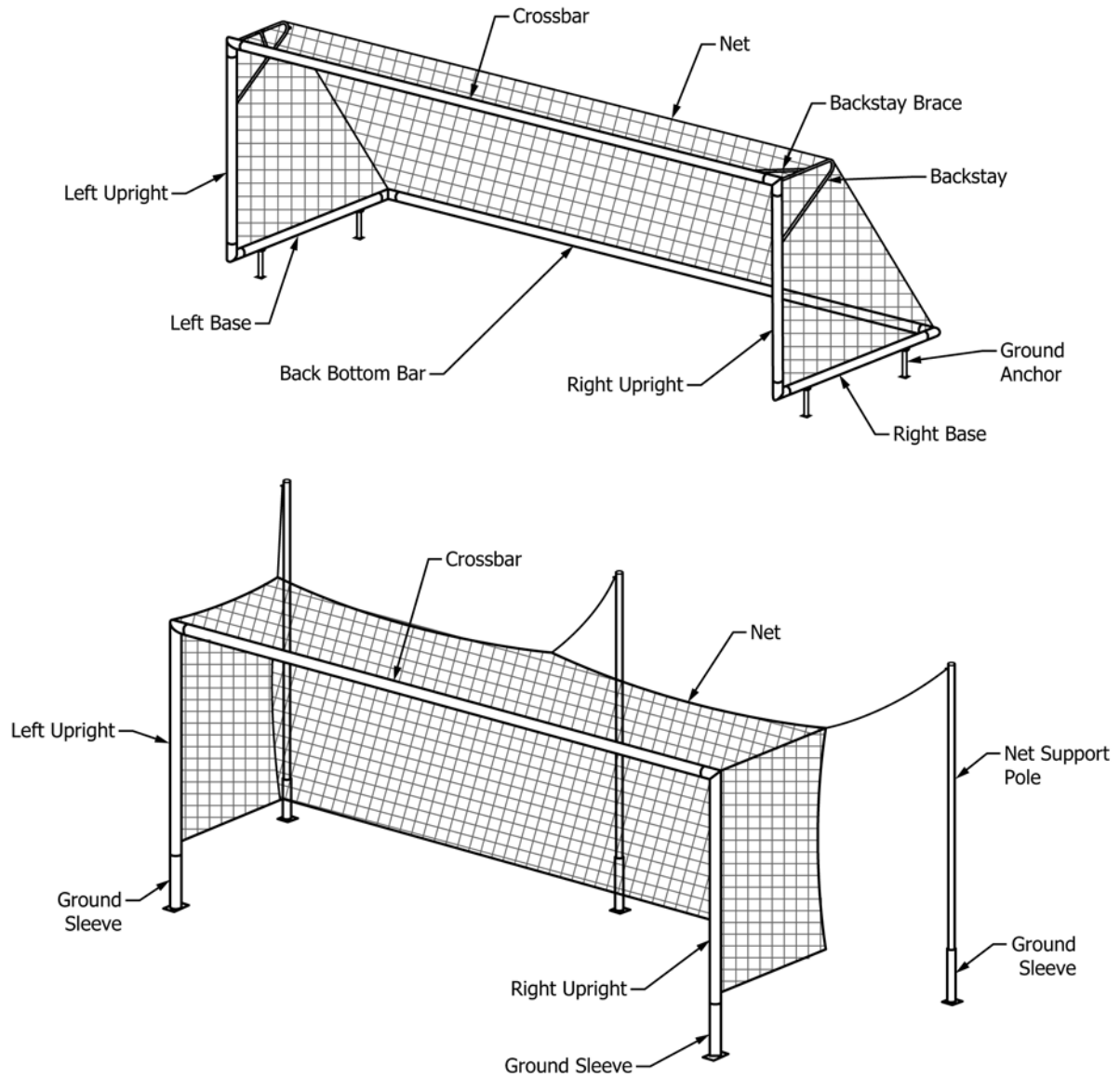

NOTE 1—Typical designs shown; variations are numerous. Depictions are not intended to limit design.

FIG. 1 Goal Components – Reference Section 3

5.6 Net attachment shall be strong enough to hold net in place during play.

5.7 Semi Permanent Goals:

5.7.1 Ground sleeves for semi permanent goals shall be adapted to the diameter of the uprights.

5.7.2 Ground sleeves shall be designed to be set in concrete, and include provision for water drainage.

5.8 The goal shall have no protrusions as determined by the gauges in Fig. 2 and the procedure below.

5.8.1 Successively place each of the three gauges over each accessible projection in any and all directions.

5.8.2 A projection is a protrusion if it extends beyond the face of any of the three gauges. See Fig. 3 and Fig. 4 for usage examples.

5.9 Anchors, hardware, and installation instruction shall be included with goal and shall be sufficient to enable the goal to

pass all testing required within this specification in any foreseeable soil conditions and recommended installations.

6. Head and Neck Entrapment

6.1 Goals shall be designed so that any accessible opening meets the following requirements.

6.2 If the field surface (ground) is the lower boundary of the opening then the opening is exempt from these requirements.

6.3 Completely bounded rigid openings.

6.3.1 A completely bounded rigid opening is considered accessible if a torso probe (Fig. 5) can be inserted into the opening to a depth of 4.0 in. or more.

6.3.2 Place the torso probe (Fig. 5) in the opening with the plane of the base of the probe parallel to the plane of the opening; rotate the probe to its most adverse orientation (that is, major axis of the base of the probe parallel to the major axis

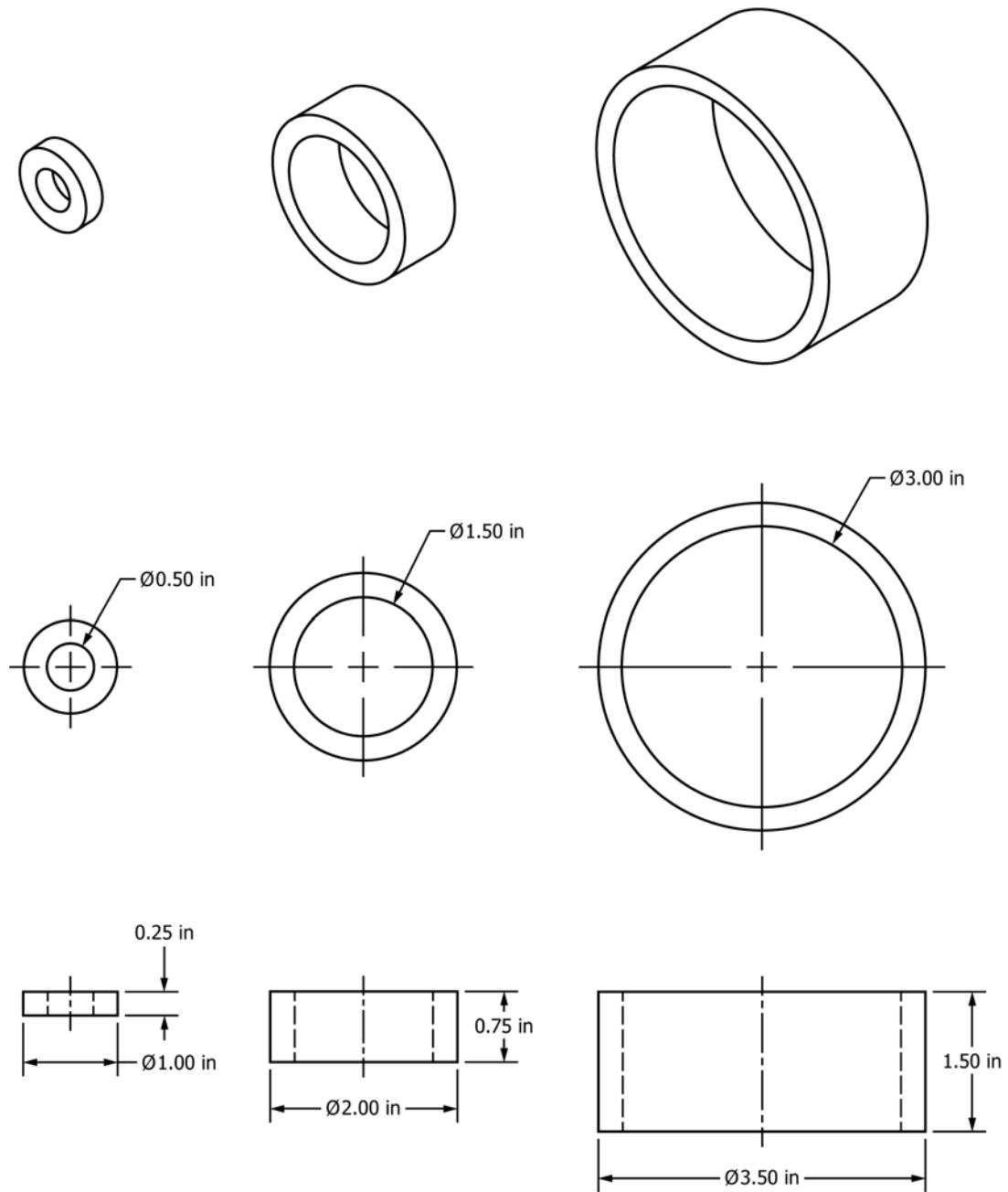

NOTE 1—Protrusion gauges to be made of any rigid material.

FIG. 2 Protrusion Gauges – Reference 5.8

of opening). If the torso probe can be inserted into the opening to a depth of 4.0 in. or more, place the head probe (Fig. 6) in the opening with the plane of the base of the probe parallel to the plane of the opening. An opening passes this test if (1) the opening does not admit the torso probe when it is rotated to any orientation about its own axis, or (2) the opening admits the torso probe and also admits the head probe. An opening fails the test if the opening admits the torso probe but does not admit the head probe.

7. Lightweight Goals

7.1 Goals with a total weight of less than 80 lb are exempt from Unanchored Goal Testing and Anchored Goal Testing in accordance with Sections 8 and 9 of this standard.

7.1.1 Total goal weight shall include all components supplied with goal including hardware, net, and net fixings.

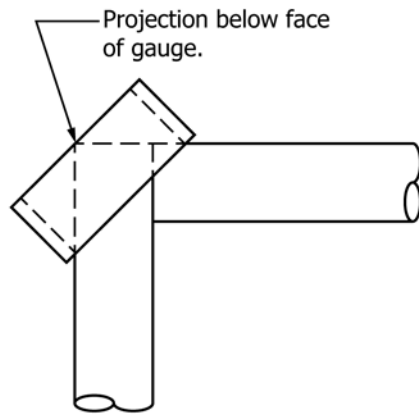

Projection below face of gauge.

PASS

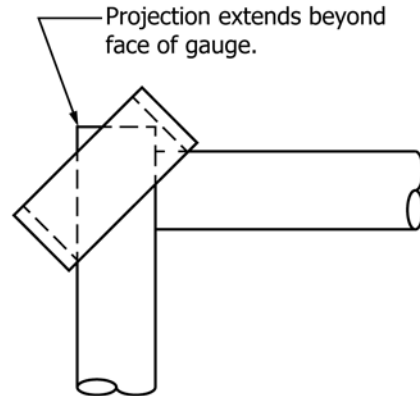

Projection extends beyond face of gauge.

FAIL

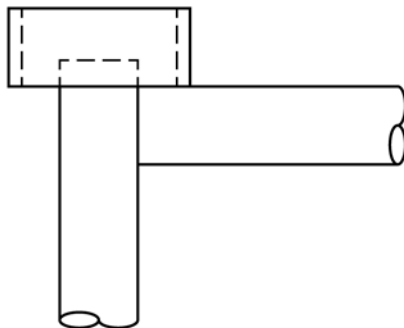

INCORRECT USE

FIG. 3 Protrusion Gauge Usage – Reference 5.8.2

7.1.2 Ground anchors are not to be included in the total goal weight, unless they are designed to remain affixed to goal during goal movement.

8. Unanchored Goal Testing

8.1 Extreme caution must be taken to protect against injury to persons and damage to property in case of goal overturning during unanchored goal testing.

8.2 Unanchored goal testing applies only to movable goals.

8.3 Goal shall be assembled in accordance with manufacturer's instruction.

8.4 Separate anchors from goal at location designed by manufacturer.

8.5 Testing shall be conducted at temperatures between 50 and 90°F.

8.6 Testing shall be conducted on a flat, level, concrete surface.

8.7 Goal passes Unanchored Goal Testing if it passes either the Swing Stability Test or the Balanced Goal Test.

8.8 *Balanced Goal Test:*

8.8.1 This test establishes that the subject goal has an equal resistance to overturning from either direction. By proving the

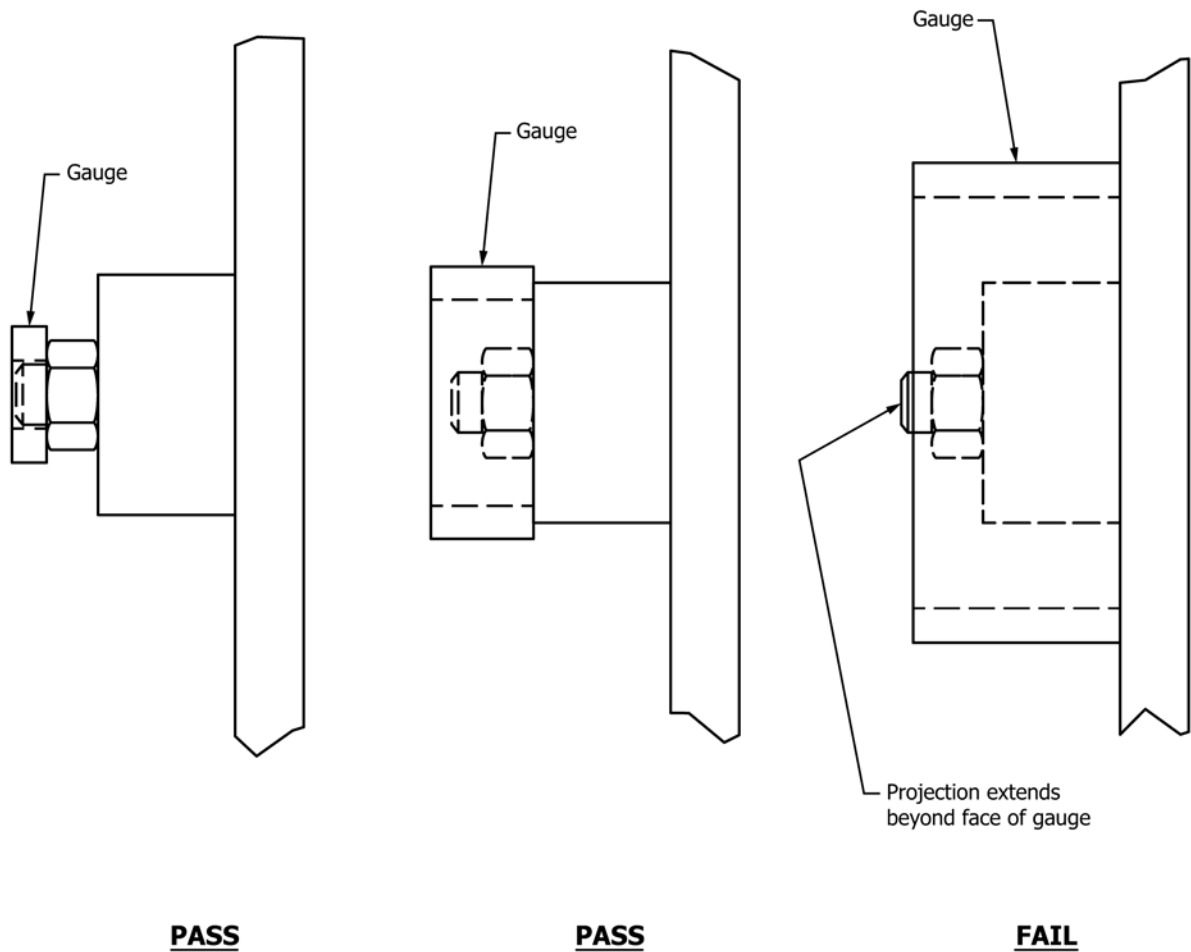

FIG. 4 Protrusion Gauge Usage – Reference 5.8.2

balance point to be between 30 and 60°, it is proven that the moment created by the upright frame is approximately equal to the moment created by the ground frame.

8.8.2 Goal is considered to be of a balanced design if it meets both of the following criteria.

8.8.3 Tip goal forward until uprights make a 30 +1/-0° angle with horizontal. Goal shall fall forward (upright frame to floor) when released from this point. See Fig. 7.

8.8.4 Tip goal forward until uprights make a 60 +0/-1° angle with horizontal. Goal shall fall backward (base frame to floor) when released from this point. See Figure 8.

8.9 *Swing Stability Test*—See Fig. 9 and Fig. 10.

8.9.1 A stop shall be placed in front of goal uprights to prevent goal from sliding forward during testing.

8.9.1.1 Stop shall have maximum thickness of 0.25 in. and be affixed to the concrete floor.

8.9.2 A vertical stop shall be placed behind the goal to prevent goal from sliding backwards during testing.

8.9.2.1 Vertical stop shall be set at a distance of 0.50 ± 0.25 in. from goal frame prior to commencing test.

8.9.2.2 Vertical stop shall not provide any resistance to goal overturning.

8.9.3 Hang a 220 lb mass from the center (±1 in.) of the crossbar.

8.9.3.1 Center of mass of load shall be 24.0 ± 1.0 in. below the bottom of the crossbar.

8.9.3.2 Connection of load to crossbar shall be by a single cord of rope with a minimum working load limit of 1000 lb.

8.9.4 From a safe position, behind the goal, using a rope of a minimum length of 10 ft, displace the load to a 30° angle to vertical and perpendicular to crossbar.

8.9.4.1 Direction of pull shall be 90 ± 10° to the 30° angle (60° to floor).

8.9.5 Let load swing freely until it comes to rest.

8.9.5.1 Pivot point of swing shall be within 2 in. of crossbar and remain stationary during testing.

8.9.6 Goal passes unanchored stability test if goal does not overturn during load swinging and does return to an upright position after load swing.

9. Anchored Goal Testing

9.1 Goal shall be assembled and anchored in accordance with manufacturer's instruction.

9.2 Testing shall be conducted at temperatures between 50 and 90°F.

9.3 Goal passes Anchored Goal Testing if it passes both Strength of Goal Frame and Stability of Goal Frame Tests.

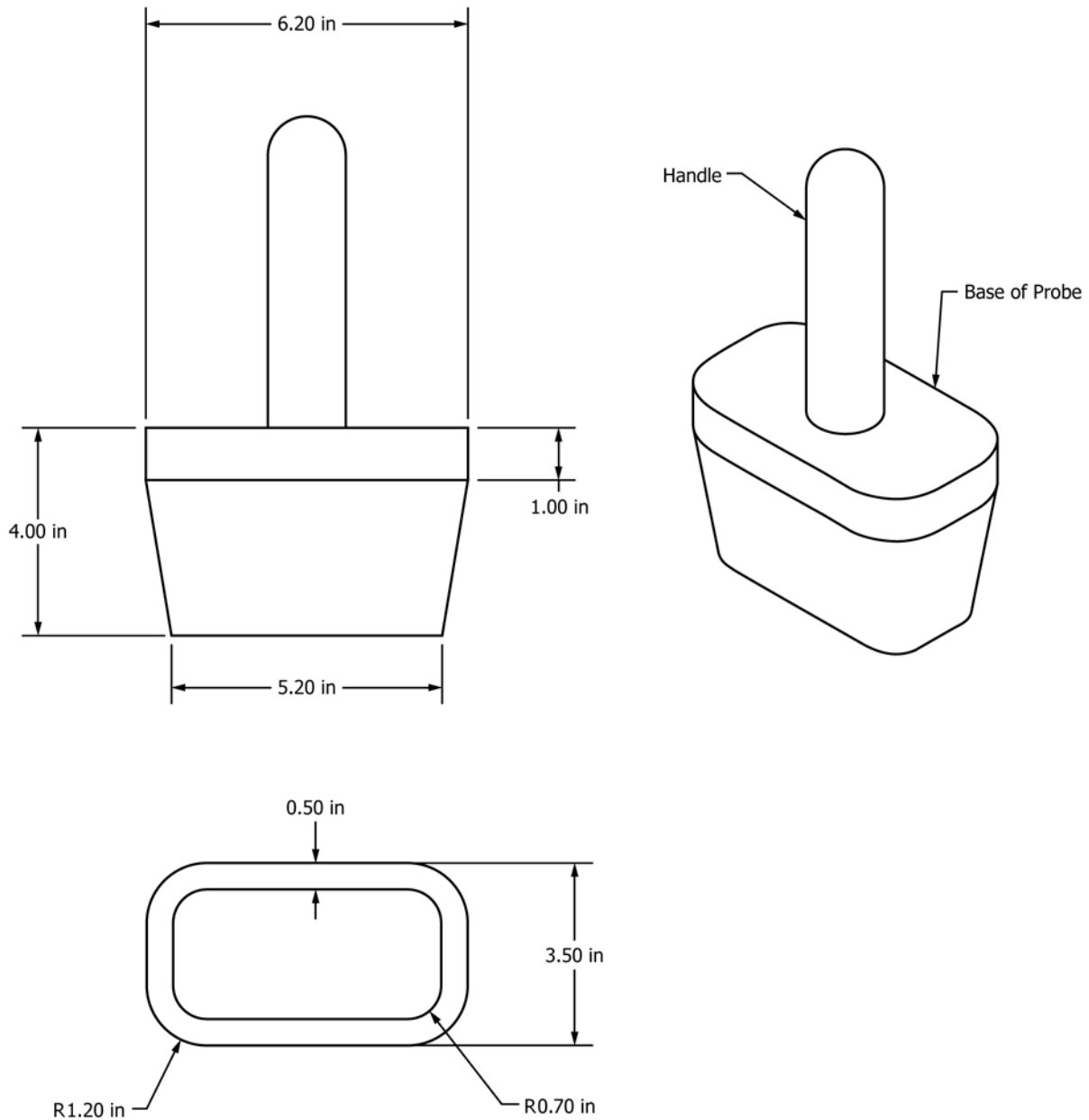

NOTE 1—Torso probe to be made of any rigid material.

FIG. 5 Torso Probe – Reference 6.3.1

9.4 Test loads shall be applied to goal by means of a webbing strap with a minimum working load limit of 1000 lb.

9.5 *Strength of Goal Frame:*

9.5.1 Apply a downward, static load of 405 lb to the center (± 1 in.) of the crossbar for 60 to 70 s. See Fig. 11.

9.5.2 Remove load and visually inspect goal frame.

9.5.3 Goal passes strength test if all of the following are true:

9.5.3.1 Frame does not collapse or overturn over duration of loading.

9.5.3.2 No component of the goal fractures during the test, as determined by thorough visual inspection.

9.6 *Stability of Goal Frame:*

9.6.1 Apply a horizontal, static load of 248 lb to the center (± 1 in.) of the crossbar for 60 to 70 s. See Fig. 12.

9.6.2 Remove load and visually inspect goal frame.

9.6.3 Goal passes stability test if all of the following are true:

9.6.3.1 Frame does not collapse over duration of loading.

9.6.3.2 Goal does not overturn over the duration of the loading.

9.6.3.3 Goal returns to an upright position after load is removed.

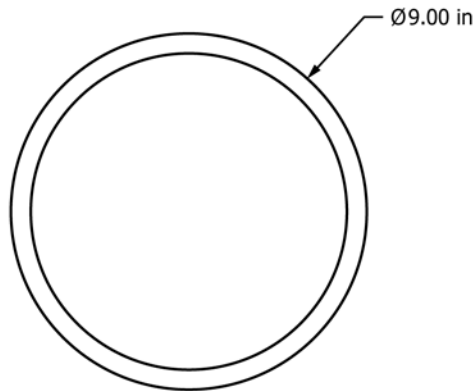
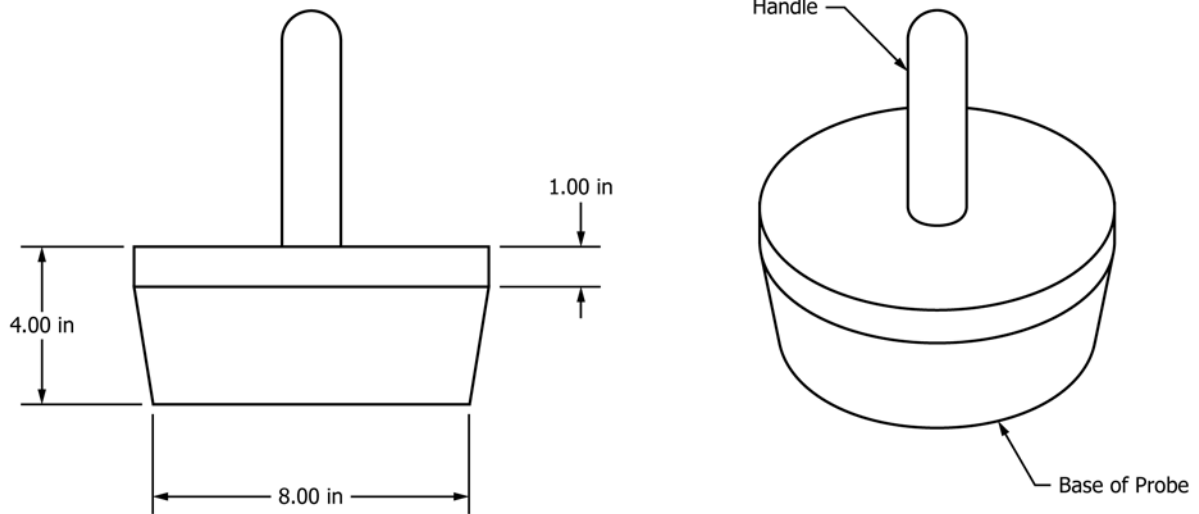

NOTE 1—Head probe to be made of any rigid material.

FIG. 6 Head Probe – Reference 6.3.2

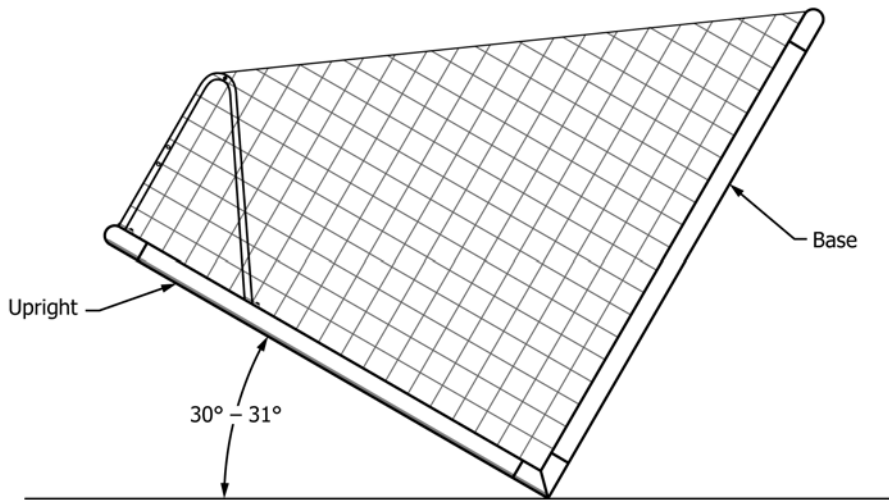

FIG. 7 Balanced Goal Test – Reference 8.8.3

9.6.3.4 No component of the goal fractures during the test, as determined by thorough visual inspection.

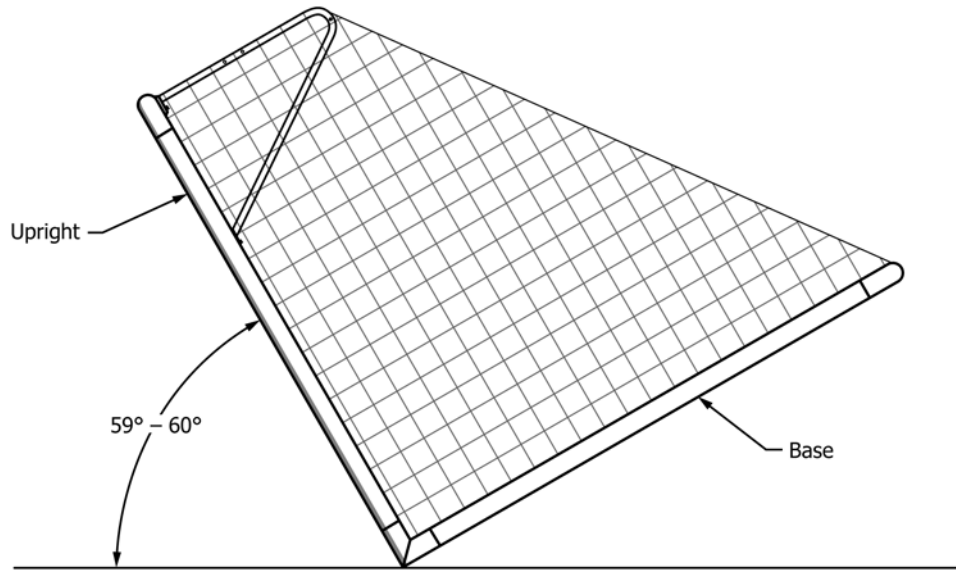

FIG. 8 Balanced Goal Test – Reference 8.8.4

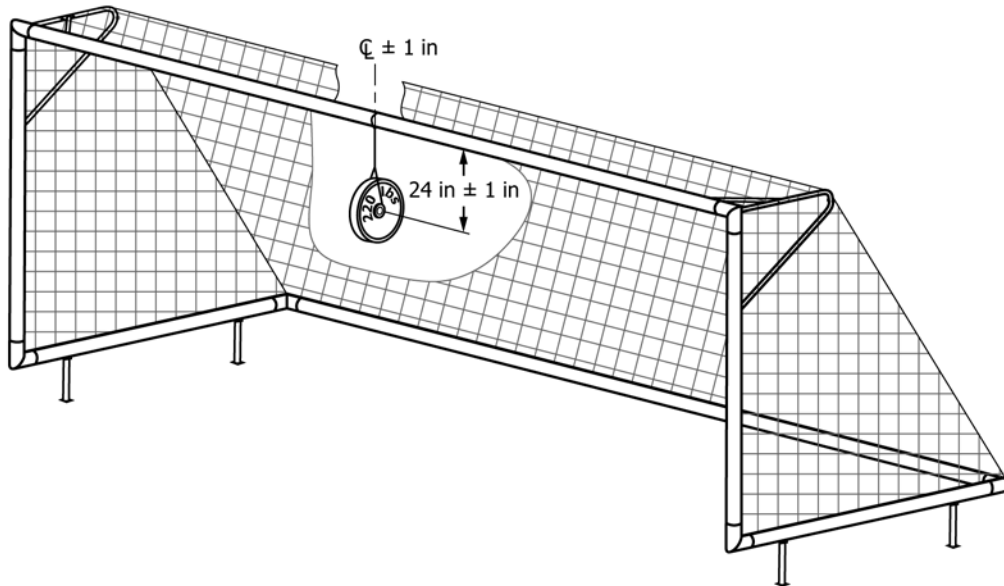

FIG. 9 Swing Stability Test – Reference 8.9

10. Assembly Instructions

10.1 Manufacturer shall provide written assembly instructions with each goal.

10.1.1 Instructions shall include anchoring installation details.

10.1.2 Instructions shall include amount and location of counterbalance weight required to make goal pass the requirements in Sections 7, 8, and 9 of this specification if counterbalance weight is the only method of anchoring used.

10.2 Manufacturer shall be able to provide instructions for a period of five (5) years from date of sale.

11. Safety Instructions

11.1 Manufacturer shall provide written safety instructions with each goal.

11.2 Safety instructions shall contain the following warnings.

11.2.1 Check for structural integrity and proper connecting hardware before every use. Replace damaged or missing parts or fasteners immediately.

11.2.2 Ensure safety/warning labels are clearly visible (placed under the crossbar and on the sides of the uprights at eye level).

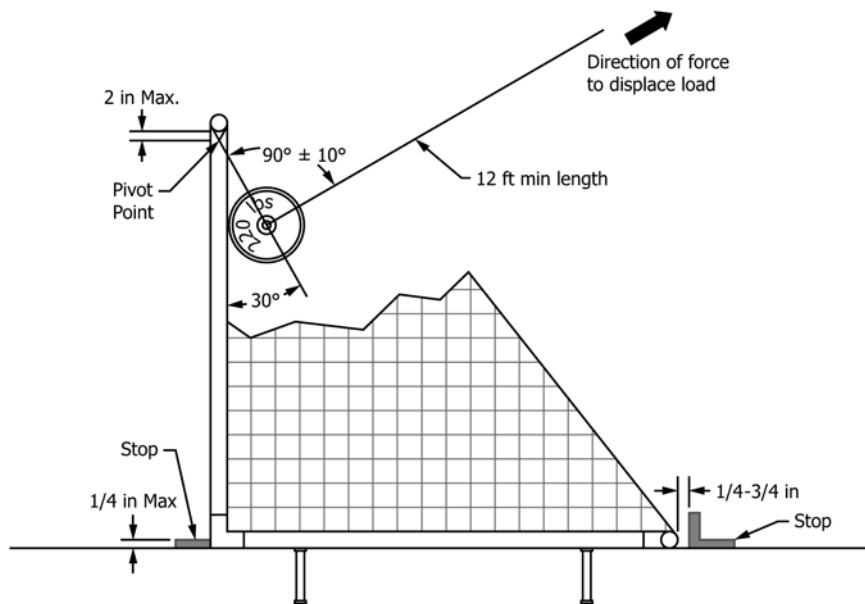

FIG. 10 Swing Stability Test – Reference 8.9

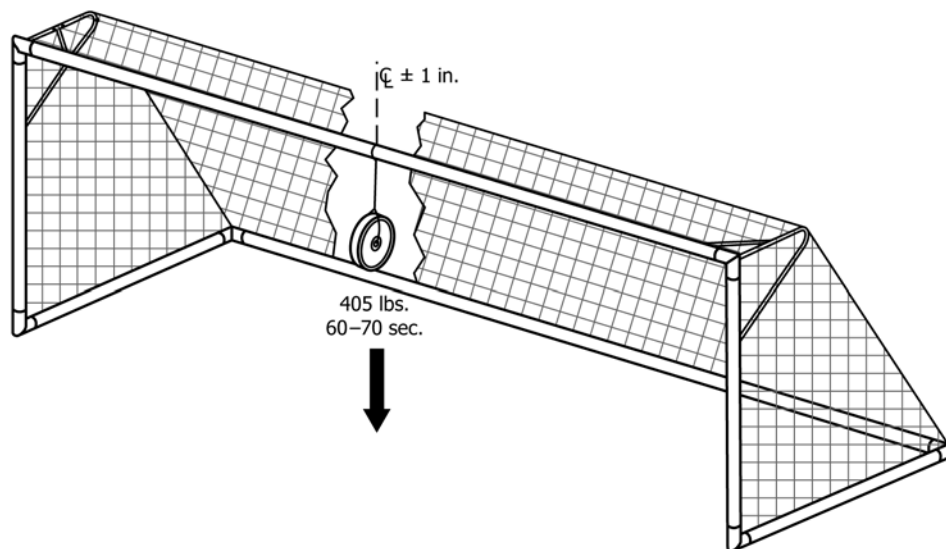

FIG. 11 Strength of Goal Frame Test – Reference 9.5.1

11.2.3 Securely anchor movable soccer goals at ALL times, except when being moved.

11.2.4 Always instruct players, managers, coaches, trainers, teachers, maintenance and all other personnel who might come into contact with the goal on the safe handling of and potential dangers associated with movable soccer goals.

11.2.5 Always exercise extreme caution when moving goals and allow adequate manpower to move goals of varied sizes and weights. Movable soccer goals should only be moved by authorized and trained personnel.

11.2.6 NEVER allow anyone to climb on the net or goal framework.

11.2.7 Movable soccer goals should only be used on LEVEL fields, NEVER on a slope or hill area.

11.2.8 Remove nets when goals are not in use.

11.2.9 Most of the tip over injuries occurred when goals were unattended. Anchor or chain one goal to another, or to nearby fence posts, dugouts, or any other similar sturdy fixture when not in use. If this is not practical, store movable soccer goals in a place where children cannot have access to them.

11.2.10 Fully disassemble goals for seasonal storage.

12. Warning Labels

12.1 Permanent warning labels shall be affixed to the goal by the manufacturer at the following locations.

12.1.1 Center of crossbar, readable from ground.

12.1.2 At eye level on each upright.

12.2 The label shall have the word WARNING in accordance with ANSI Z535.4 with respect to color and letter height.

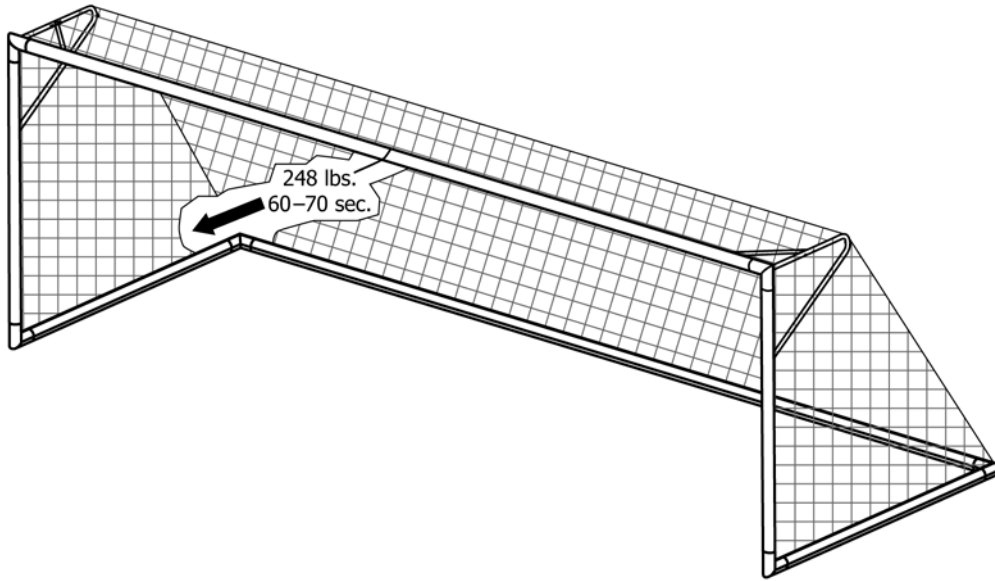

FIG. 12 Stability of Goal Frame Test – Reference 9.6.1

12.3 The label(s) shall include:

12.3.1 This goal is not to be stored or used on a slope or hill area.

12.3.2 Check to insure that all fastenings are fully tightened before using this product.

12.3.3 Check fastenings periodically afterwards.

12.3.4 This goal shall be secured against overturning at all times.

12.3.5 Do not climb on the net or framework.

12.4 Appropriate example graphical symbols are shown in Fig. 13.

13. Goal Markings

13.1 Goal shall be marked with the following manufacturer's information on one or both uprights.

13.1.1 Name of manufacturer.

13.1.2 Means of contacting manufacturer including at least one of the following:

⚠ WARNING



Never climb on goal.
Goal can fall over causing serious injury or death.

⚠ WARNING

ALWAYS ANCHOR GOAL
Unsecured goal can fall over causing serious injury or death.

⚠ WARNING

This goal should be securely anchored at all times • This goal is not to be stored or used on a slope or hill area • Check that all fastenings are fully tightened before using this product • Check fastenings periodically after using goal • Goal shall be secured against **overturning** at all times • Do not climb on net or framework • This goal is designed to be used for soccer only

FIG. 13 Warning Label Examples – Reference Section 12



FIG. 14 Specification Label – Reference 13.3

- 13.1.2.1 Address.
- 13.1.2.2 Phone number.
- 13.1.2.3 Website.

13.2 Goal shall not be marked in any way to imply it is safe for goal to be unanchored at any time.

13.2.1 Goals shall not be labeled “tip resistant goal” or “tilt resistant goal.” This statement could mislead users regarding goal anchoring requirements.

13.3 Any goal meeting all criteria of this specification shall be marked “Meets Safety and Performance Specification ASTM F2950-14 when assembled according to manufacturer’s instruction.” See Fig. 14, for example.

14. Compliance

14.1 No product within the scope of this ASTM standard shall, by any means, indicate compliance to the standard unless it conforms to all requirements herein.

14.2 Claims of partial compliance to this ASTM standard are not permitted.

15. Keywords

- 15.1 soccer goals

ASTM International takes no position respecting the validity of any patent rights asserted in connection with any item mentioned in this standard. Users of this standard are expressly advised that determination of the validity of any such patent rights, and the risk of infringement of such rights, are entirely their own responsibility.

This standard is subject to revision at any time by the responsible technical committee and must be reviewed every five years and if not revised, either reapproved or withdrawn. Your comments are invited either for revision of this standard or for additional standards and should be addressed to ASTM International Headquarters. Your comments will receive careful consideration at a meeting of the responsible technical committee, which you may attend. If you feel that your comments have not received a fair hearing you should make your views known to the ASTM Committee on Standards, at the address shown below.

This standard is copyrighted by ASTM International, 100 Barr Harbor Drive, PO Box C700, West Conshohocken, PA 19428-2959, United States. Individual reprints (single or multiple copies) of this standard may be obtained by contacting ASTM at the above address or at 610-832-9585 (phone), 610-832-9555 (fax), or service@astm.org (e-mail); or through the ASTM website (www.astm.org). Permission rights to photocopy the standard may also be secured from the ASTM website (www.astm.org/COPYRIGHT/).